



- ABS JUNCTION BOX
- IP67 PROTECTION RATING
- WORKING TEMPERATURE: -20 °C +60 °C
- 4/6 WIRES LOAD CELLS CONNECTION

	DESCRIPTION	CODE
EQUALIZATION BOARD		
	Up to 4 load cells connection. <ul style="list-style-type: none"> ■ 4+1 polyamid cable glands M16x1.5 - plugs. ■ 4+1 PVC end-fittings for sheath. 	CE41N CE41NR
	Up to 8 load cells connection. Lightning and electrical shock protection device. <ul style="list-style-type: none"> ■ 8+2 polyamid cable glands M16x1.5 - plugs. ■ 8+2 PVC end-fittings for sheath. 	CE81PN CE81PNR
PARALLEL CONNECTION BOARD		
	Up to 4 load cells connection.	CIP67N
	Up to 4 load cells connection. <ul style="list-style-type: none"> ■ 4+1 polyamid cable glands M16x1.5 - plugs. ■ 4+1 PVC end-fittings for sheath. 	C41N C41NR

CERTIFICATIONS

- EAC** Complies with the Eurasian Customs Union standards
- UK CA** Equivalent of the CE marking for the United Kingdom

DIMENSIONS (mm)

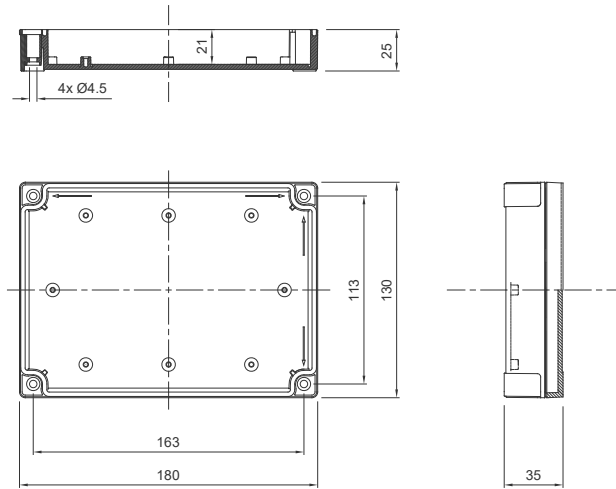

ELECTRICAL CONNECTIONS

TO CONNECT TO THE INSTRUMENT USE:

- 4-wire connection: shielded cable 4x0.5 mm² (minimum section).
- 6-wire connection: shielded cable 6x0.2 mm² (minimum section).

CE41N - CE41NR

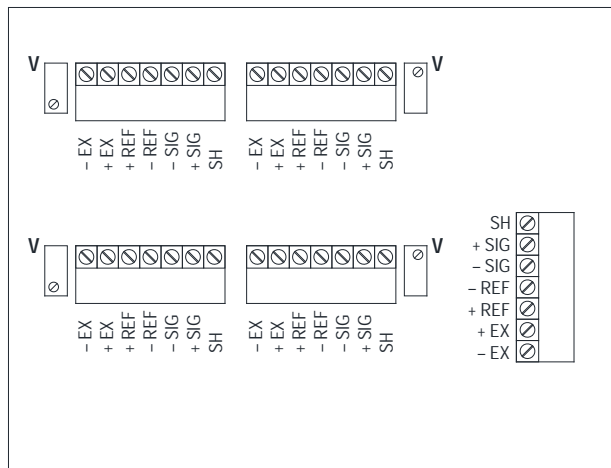

6-WIRES LOAD CELLS CONNECTION

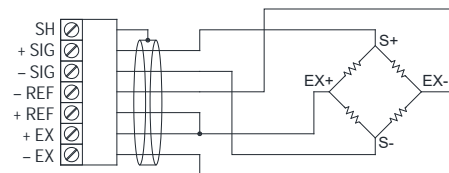

4-WIRES LOAD CELLS CONNECTION

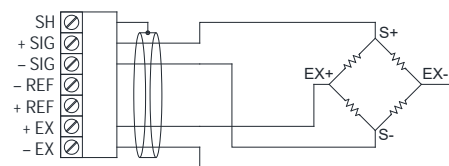

4-WIRES OUTPUT CABLE WITH 4 WIRES LOAD CELL

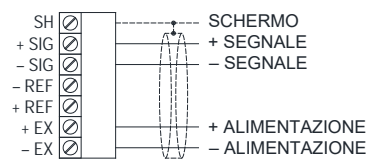

6-WIRES OUTPUT CABLE WITH 6 WIRES LOAD CELL

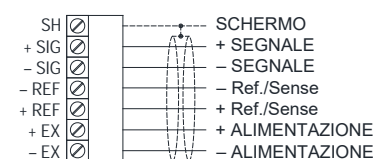

6-WIRES OUTPUT CABLE WITH 4 WIRES LOAD CELL

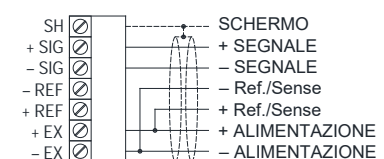

ELECTRICAL CONNECTIONS

CE81PN - CE81PNR

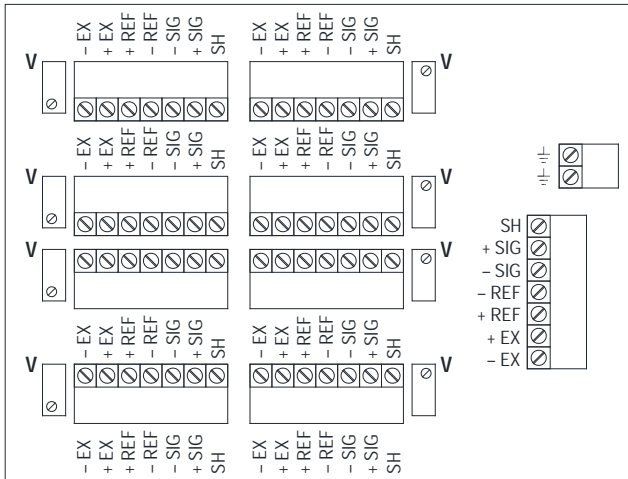

6-WIRES LOAD CELLS CONNECTION

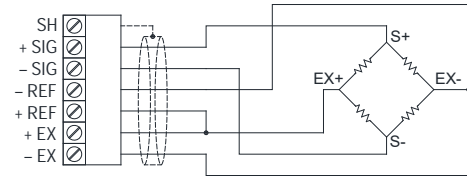

4-WIRES LOAD CELLS CONNECTION

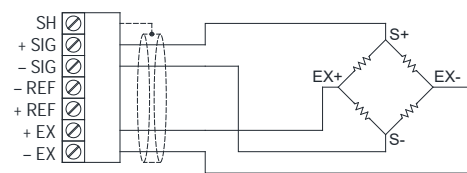

4-WIRES OUTPUT CABLE WITH 4 WIRES LOAD CELL

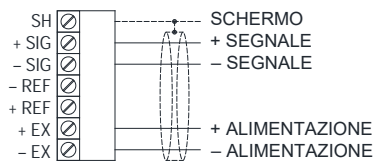

6-WIRES OUTPUT CABLE WITH 6 WIRES LOAD CELL

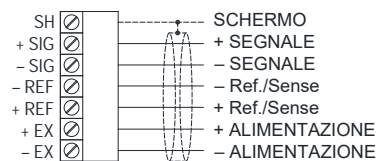

6-WIRES OUTPUT CABLE WITH 4 WIRES LOAD CELL

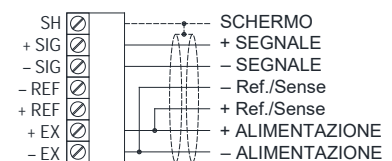

ELECTRICAL CONNECTIONS

CIP67N - C41N - C41NR

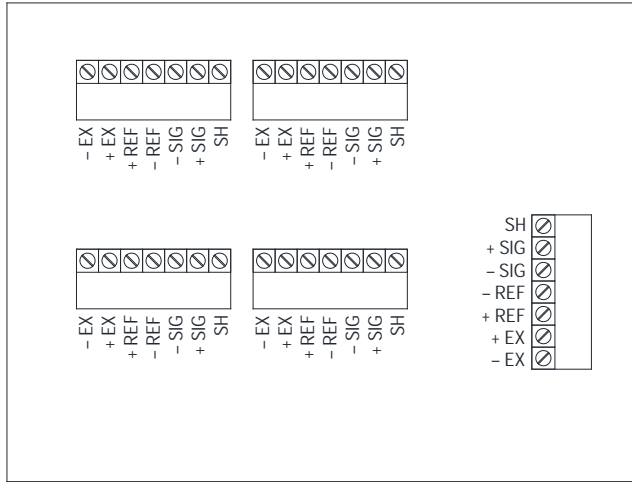

6-WIRES LOAD CELLS CONNECTION

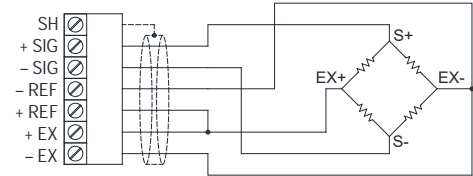

4-WIRES LOAD CELLS CONNECTION

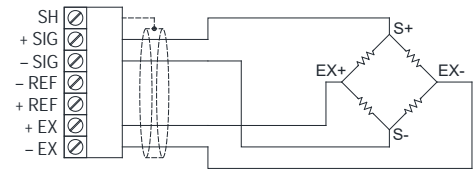

4-WIRES OUTPUT CABLE WITH 4 WIRES LOAD CELL

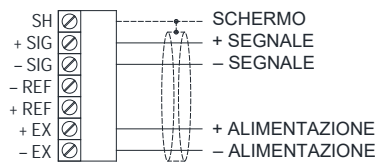

6-WIRES OUTPUT CABLE WITH 6 WIRES LOAD CELL

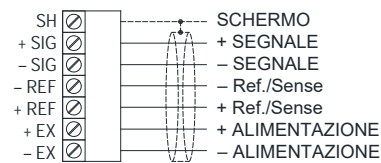

6-WIRES OUTPUT CABLE WITH 4 WIRES LOAD CELL

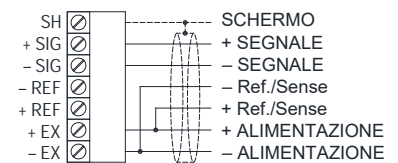

EQUALIZATION PROCEDURE

WARNING!

- For load cells with 2 mV/V sensitivity the difference between the sensitivities must not be greater than 0.1 mV.
For load cells with 3 mV/V sensitivity the difference between the sensitivities must not be greater than 0.15 mV.
- The board is equipped with a 50 Ω potentiometer for each load cell.

PROCEDURE WITH TESTER (mV and VDC scale):

Example with 4 load cells and a sample weight of 978 kg:

1. Check that the voltage value measured on the test points V is 0 mV; if necessary adjust the potentiometers until the correct value is obtained.
2. Place the sample weight in correspondence with each load cell, noting the weight indicated on the display each time.
Example: 1008 kg, 998 kg, 973 kg and 985 kg.
3. Measure the supply voltage between +EX and -EX terminals. Example: 4.87 VDC.
4. Adjust the potentiometers related to the higher weight values, leaving the lowest one unchanged; the mV value to be measured on the respective test points is given by the following formula:
$$[(\text{load cell value to be adjusted} - \text{lowest load cell value}) \div \text{lowest load cell value}] \times \text{supply voltage value} \times 1000$$
$$[(1008 - 973) \div 973] \times 4.87 \times 1000 = 175 \text{ mV}$$
$$[(998 - 973) \div 973] \times 4.87 \times 1000 = 125 \text{ mV}$$
$$[(985 - 973) \div 973] \times 4.87 \times 1000 = 60 \text{ mV}$$
5. Adjust the potentiometers of the three load cells until the following values are obtained respectively:
175 mV, 125 mV, 60 mV
6. Place the sample weight in correspondence of each load cell, the display must now show the same value for all of them.
7. Remove the sample weight and zero the tare, then place the sample weight in the middle and calibrate the instrument (see the instrument's user manual).

PROCEDURE WITHOUT TESTER:

Example with 4 load cells and a sample weight of 978 kg:

1. Turn the potentiometers' screw counterclockwise until to 0 Ω.
2. Place the sample weight in correspondence with the CL1 load cell and take note of the value shown on the display; repeat the same operation for all load cells.
Example: CL1 = 1008 kg CL2 = 998 kg
 CL3 = 973 kg CL4 = 985 kg
3. Adjust the potentiometers related to the higher weight values (W1, W2, W4), leaving the lowest one unchanged (W3).
4. Place the sample weight in correspondence with the CL1 load cell; by adjusting the potentiometer W1 change the value shown on the display from 1008 kg to 973 kg.
5. Place the sample weight in correspondence with the CL2 load cell; by adjusting the potentiometer W2 change the value shown on the display from 998 kg to 973 kg.
6. Place the sample weight in correspondence with the CL4 load cell; by adjusting the potentiometer W3 change the value shown on the display from 985 kg to 973 kg.
7. Place the sample weight in correspondence with the CL3 load cell and take note of the value shown on the display, for example 966 kg.
8. Place the sample weight in correspondence with the CL1 and adjust the potentiometer W1 until 966 kg is displayed.
9. Place the sample weight in correspondence with the CL2 and adjust the potentiometer W2 until 966 kg is displayed.
10. Place the sample weight in correspondence with the CL4 and adjust the potentiometer W3 until 966 kg is displayed.
11. Place the sample weight in correspondence with the CL3 and take note of the value shown on the display, for example 962 kg.
12. Repeat the procedure several times until the display shows the same weight value for all four load cells.
13. Remove the sample weight and zero the tare, then place the sample weight in the middle and calibrate the instrument (see the instrument's user manual).